

Gelb markiert = Standard Rüstzustand
der Firma Stiglmaier

Tower Crane
Grue à tour

Turmdrehkran 32 K

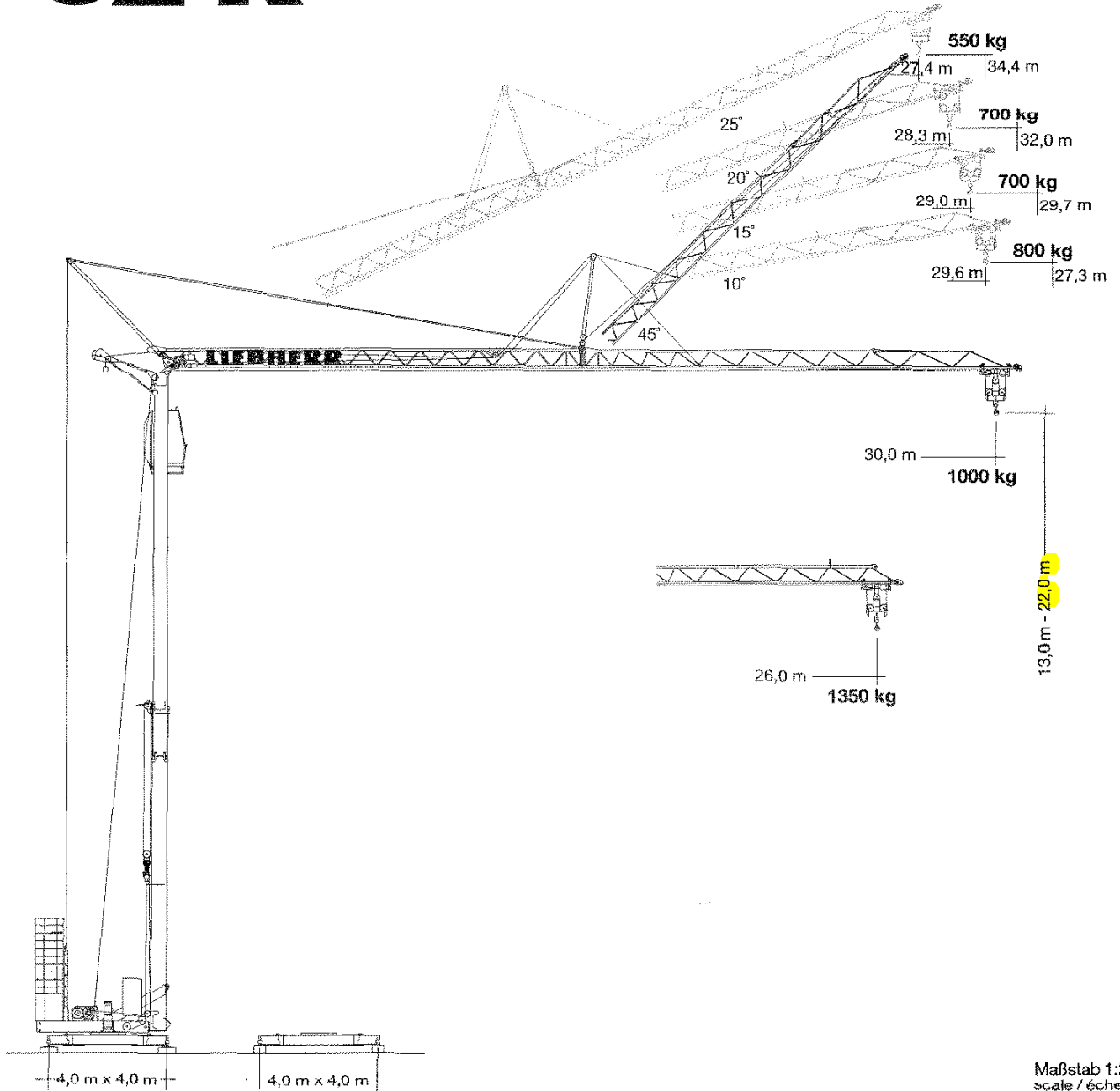

Maßstab 1:200
scale / échelle

LIEBHERR

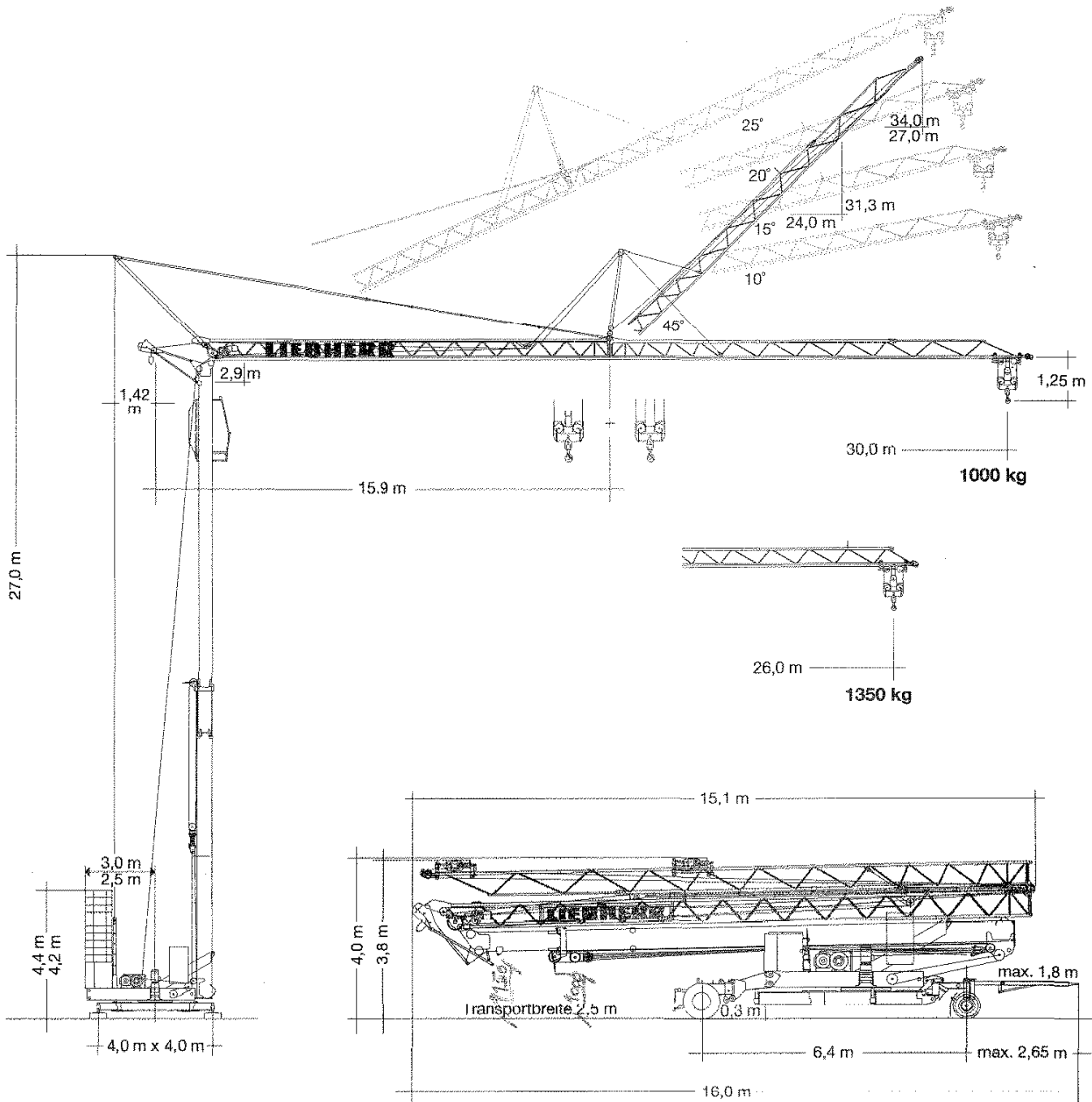

Transportgewicht 18500 kg
 Transport weight approx.
 Poids de transport env.

Gewicht

Weight

Poids

Zentralballast Central ballast weight Lest de base		1080 kg	Konstruktionsgewicht ca. Dead weight approx. Poids de la construction env.	11800 kg
Gegengewicht Counterweight Contrepoids	r = 3,0 m r = 2,5 m	17000 kg 18500 kg		

* Umrechnung der Einheiten für Kräfte 1 kp = 10 N; 10 kN = 1 Mp. / Conversion of the units for forces. / Conversion des unités des forces.

32 K

Ausladung und Tragfähigkeit

Radius and capacity

Portée et charge

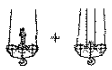

Auslegerlänge Length of jib Longueur de flèche m	 max. kg		m/kg																			
	m/kg		11,0	12,0	13,0	14,0	15,0	16,0	17,0	18,0	19,0	20,0	21,0	22,0	23,0	24,0	25,0	26,0	27,0	28,0	29,0	30,0
30,0	2,9-19,4 1750	-11,3 3500	3500	3230	2915	2650	2430	2240	2070	1930	1800	1690	1585	1490	1410	1340	1270	1210	1150	1095	1050	1000
26,0	2,9-21,2 1750	-12,2 3500	3500	3500	3230	2940	2695	2485	2300	2140	2000	1880	1770	1670	1580	1490	1420	1350				

	 max. min. 2,9 m		① Max. Hakenhöhe Max. hoisting height Hauteur sous crochet max. ② Max. Ausladung Max. radius Portée max. ③ Tragfähigkeit (Zwischenwerte siehe Betriebsanweisung) Capacity Charge (Values in between see instruction manual) (Valeurs intermédiaires voir manuel d'instructions)											
	10°			15°			20°			25°				
	①	②	③	①	②	③	①	②	③	①	②	③		
30,0	27,3	29,6	800	29,7	29,0	700	32,0	28,3	700	34,3	27,4	550		
	25,7	20,3	1300	27,8	22,0	1000								
26,0	26,7	25,6	1150	28,7	25,2	1000	30,7	24,6	700	32,6	23,8	550		
	26,3	23,2	1300											

Geschwindigkeiten

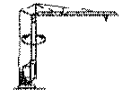
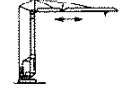
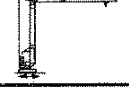
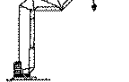
Speeds / Vitesses

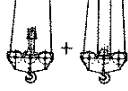
	U/min 0-0,8 st./min tr./min	1,5 kW
	20,0 / 40,0 m/min	1,6 / 2,8 kW
	25,0 m/min	2 x 1,0 kW
	0-45° ca. 38 sec.	2,2 kW

Hubwerk Hoist unit Mécanisme de levage	Stufe Step Cran	kg	m/min
	1	1750	5,0
	2	1750	20,0
	3	1300	40,0
	1	3500	2,5
	2	3500	10,0
	3	2600	20,0

Leitungsquerschnitt bei 380 V bis 28,0 m 4 x 10 mm²
Cross section of cable up to
Section de câble à jusqu'à

Betriebsspannung 380 V
Operating voltage
Tension de service

Frequenz 50 Hz
Frequency
Fréquence

Gesamtmotorenleistung max. 19,5 kW / 26,0 kVA
Total motor output
Puissance totale des moteurs

Technische Kenngröße nach BGL

Technical nominal size according to the construction machinery list (BGL)
Grandeur caractéristique suivant le barème d'emploi des appareils (BGL)



Technische Daten - Technical data

Caractéristiques techniques

Aufstellvorgang

Erection procedure

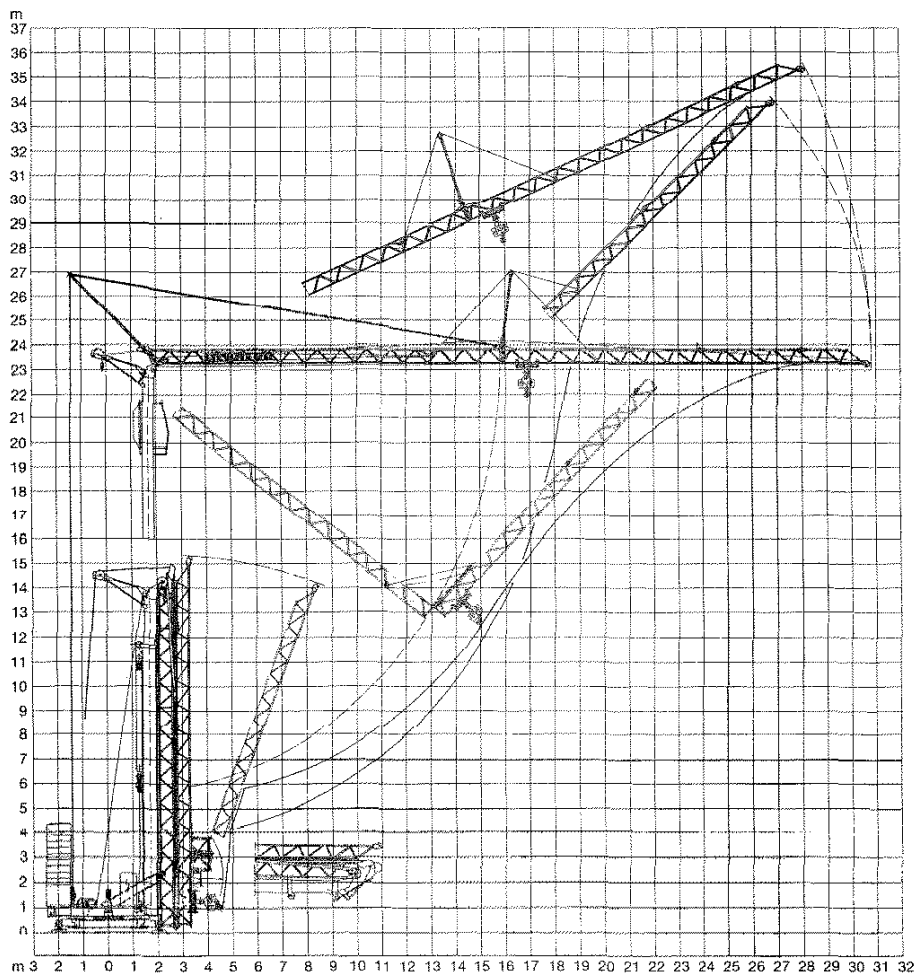

Déroulement de montage



Kolli-Liste

Packing List

Liste de colisage

Pos. Item Rep.	Anz. Qty. Qté			L (m)	B (m)	H (m)	kg
1	1	Transportachse vorne Tra 100 KY 1 Road transport axle front Essieux de transport avant		3,00	1,13	0,97	660
2	1	Transportachse hinten Tra 120 GY 1 Road transport axle behind Essieux de transport arrière		1,90	2,50	1,05	1150
3	1	Kiste mit Seilen und Kleinteilen Case with ropes and small parts Caisse avec câbles et pièces détachées		1,00	0,80	1,00	450

Datenblatt Nr. 120 P - 2925 - H 1 B 3 DIN 15018 und OENORM T 3 - 03.92
Data sheet
Feuille de caractéristiques

Konstruktionsänderungen vorbehalten!
Subject to alterations!
Sous réserves de modifications!

Printed in Germany

Nehmen Sie Kontakt auf mit
Contact

Mettez-vous en rapport avec
LIEBHERR-WERK BIBERACH GMBH, Postfach 1663, D-7950 Biberach an der Riß 1
Telefon (07351) 41-0, Telex 71 809, Telefax (07351) 41225